

# FORCE 10

## GOURMET GALLEY RANGE

Propane and Natural Gas Models

### INTRODUCTION

Thank you for selecting the Force 10 Gourmet Galley Range. Your unit was carefully inspected and tested at our factory. We take pride in producing one of the finest and safest gas ranges manufactured.

Because of the continuing refinement of our product designs, your range may possess features not discussed in the manual. We have tried to supply all the information you might need, so please take time to read this manual before installing and using your unit.

Force 10 is strongly against unauthorized modification of this product, but we do encourage you to correct problems that may arise by undertaking the simple repairs and maintenance described in this manual.

The most important reason for reading the manual carefully is that many of its instructions are essential to the safe operation of your range.

Should any questions arise that are not addressed in this manual, we ask that you contact your dealer or Force 10, quoting both the model and serial number printed on the product identification label located on the side of your range.

We welcome any opportunity to be of assistance:

**FORCE 10 MARINE LTD.**  
**23080 Hamilton Road**  
**Richmond, BC Canada V6V 1C9**  
**Tel: (604) 522-0233**  
**Fax: (604) 522-9608**

**Any recommendation or advice given by Force 10 Marine Ltd. or any of its employees is solely an accommodation to the customer, and should not be relied upon by the customer without an independent verification of its applicability to the customer's particular situation.**



## **SAFETY AND INSTALLATION**

Some Force 10 Galley Range models are specifically equipped to burn Propane Gas, while other models are equipped to use Compressed Natural Gas (CNG). Propane and CNG are **not** interchangeable fuels. It is therefore important to ensure that the model you have selected is the correct one for the type of fuel system you intend to use. If natural gas is used in a propane stove the burner flames will be inadequate for cooking. If propane is used in a stove fitted for CNG, burner flames will be unacceptably and **dangerously** high.

Recommended installations for both propane and CNG systems are outlined in this manual. Follow only the instructions that are applicable to your specific model of Galley Range. If, at some future date, you want to convert your propane or CNG range to the other fuel, a conversion kit can be obtained from Force 10. The model and serial number of your range are required to obtain the correct kit.

Propane and natural gas are excellent and convenient galley fuels if used in accordance with the installation and safety procedures listed in this manual. If these procedures are ignored, there is a danger of fire and explosion. We have done our best to design and construct your Gourmet Galley Range to be the safest marine galley range available. You can do your part to ensure safety by following these installation and testing procedures.

All valves (both tank and solenoid) must be closed when the boat is unattended. They must also be closed **immediately** in any emergency. Force 10 recommends that manual cylinder valves be closed while appliances are not in operation.

### **Gas Pressures**

Propane gas pressures can vary depending on country of origin. This may necessitate a change to your propane tank regulator and a need to adapt your galley range to the new pressure. The following is a list of Orifices/By Pass and Propane pressures available.

Application	Gas	Pressure		Orifice Size (mm) / By Pass (mm)			
		mbar	Water Column	Small Burner	Large Burner	Broiler	Thermostatic Oven Burner
N. America	Propane	30	12"	0.77/ 0.35	1.00/ 0.46	0.68/ 0.62	0.77/ 0.35
Europe	Propane	37	15"	0.71/ 0.35	0.90/ 0.46	0.62/ 0.62	0.77/ 0.35
Europe	Propane	50	20"	0.60/ 0.26	0.80/ 0.35	0.58/ 0.58	0.77/ 0.35
Europe	Butane	28	11"	0.71/ 0.35	0.90/ 0.46	0.62/ 0.62	0.77/ 0.35
N. America	CNG	15	6"	1.08/ 0.35	1.42/ 0.46	1.07/ 0.62	1.08/ 0.35

Our Galley Ranges are built for North American propane pressure and orifice sizes, unless ordered otherwise. Adapter kits are available from Force 10.

### **Propane and Butane (LPG) Fuel System**

**\*\* Follow these instructions for propane model Galley Ranges only**

1. Buy your cylinder, gauge, master solenoid valve and hose from a reputable marine dealer, or your local LPG service center. Do **not** use unreliable or worn-out equipment.

We specifically recommend that only a high quality regulator be used with your Force 10 Galley Range. It must be set at 12" water column. A higher pressure could result in a dangerously high flame setting. If you question the quality or pressure setting of the regulator, please have it inspected by your local LPG service center.

2. Locate the cylinder and regulator in a housing vented to the open air (preferably on the deck or cabin top) isolated from the hull interior by a vapor tight enclosure.

Propane is heavier than air. It can therefore accumulate at the bottom of enclosed compartments despite the provision of overhead ventilation. To allow it to safely drain overboard, the housing in which the cylinder is installed must be vented at the bottom. A pipe or hose of at least 1" (25mm) i.d. running on a downward slope to an outlet on the hull exterior is ideal. Position the vent above the water line, and at least two feet from any hull opening to the boat interior or engine exhaust.

We recommend the installation of a vapor monitor on your boat with all propane fueled devices.

3. Propane is a two-phase (liquid/vapor) fuel, and only vapor withdrawal from the tank is safe. Firmly mount the cylinder, right side up, to ensure that liquid withdrawal does not occur.
4. We recommend that a solenoid valve, which can be controlled by a switch located in your cabin, be installed next to the manual cylinder valve. The cylinder valve outlet and the 9 or 12 VDC solenoid valve should be clean and dry when they are connected to each other.

Unnecessary attempts to seal this connection with substances like pipe dope or Teflon tape can result in the introduction of foreign materials into the system that can plug the tiny appliance orifices.

5. Tighten the solenoid valve to the cylinder valve outlet properly. Use a 7/8" (22mm) or adjustable wrench - not a pair of pliers - and apply approximately 50 ft-lbs. (68Nm) of torque.
6. A 0-300 psi (0-20 bar) pressure gauge should be installed next to the solenoid valve on its downstream side. Again, the fittings should be clean and dry. It is not necessary to use pipe dope or Teflon tape for these connections.



7. Install the regulator downstream from the pressure gauge with its vent port pointing downward, which prevents spray or deck wash from entering the fuel system.

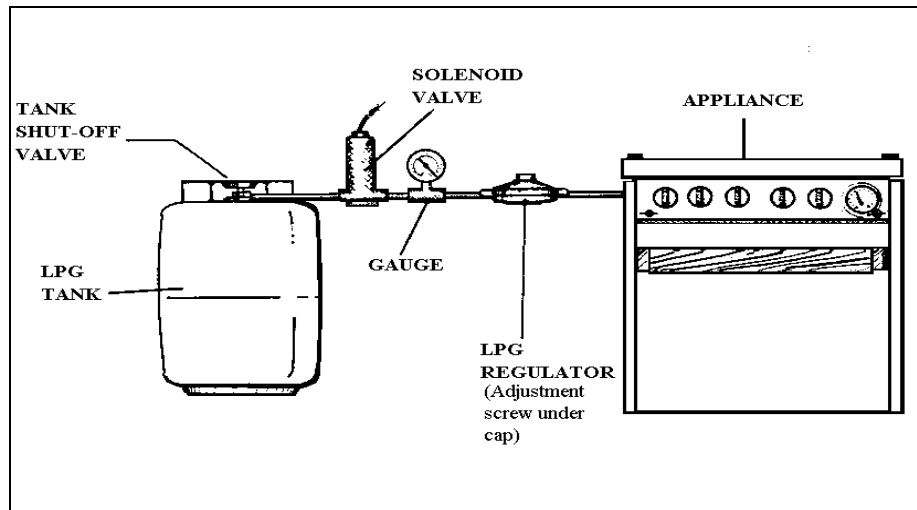

### Recommended LPG System Installation

*\*\* In some cases the solenoid valve is installed on the low pressure side of the system (i.e. after the LPG regulator). See solenoid manufacturers' instructions for proper installation.*

1. Starting from the propane tank itself, the fuel line attachments should occupy the following positions: (a) the tank shut-off valve, (b) the solenoid valve, (c) the pressure gauge, (d) the regulator, and (e) the range itself.
2. Affix the caution label plate supplied with your Galley Range in the immediate vicinity of the gas cylinder in a place where it will be plainly visible.
3. If the range is a gimballed model, the gas supply line should be a flexible, fire-resistant hose, UL/CGA approved for use with propane systems, with 3/8" (10mm) forged female flare nuts machined crimped on each end.

If your range is a built-in style, you should use either soft copper tubing or a UL/CGA approved gas hose with 3/8" (10mm) forged female flare nuts machine crimped onto each end.

Because every connection is a potential leak, the fuel line should be one continuous length of hose or tubing. Do **not** make a "T" off ant fuel line between an existing appliance and the gas cylinder to feed another appliance. (You may install a "T" connection only within the fuel tank's enclosure, so any leakage is contained.)

4. Be sure you do not kink the hose or piping connecting the regulator with the range by bending it too sharply during installation - remember that the pressure (North American) on the downstream side of the regulator is less than .433 psi (28 mbar).
5. Protect the hose against vibration and damage by securing it tightly to bulkheads and hull side with non-corrosive ties or clamps which will not cut, abrade or pinch it.

On gimballed models, the last two feet (60 cm) of the downstream end of the hose should be unattached to bulkheads or the hull side to allow the range to swing freely on its gimbals.

6. Fuel lines must be protected by close-fitting grommets and sealants where they pass through decks or bulkheads, and the passage must be made vapor-tight. They should be installed so that they are readily accessible to inspection.

### **Natural Gas (CNG) Fuel System**

**\*\* *Follow these instructions for natural gas model Galley Range ONLY.***

1. Buy your cylinder, gauge, regulator and fuel line from a reputable marine dealer, or your local CNG service station. Do **not** use unreliable or worn-out equipment.
2. Choose the location for the CNG cylinder away from any potential fire hazards, such as a gasoline-fueled engine, a hot manifold or exhaust riser. Should the CNG cylinder be adjacent to a fire and the safety valve rupture disc reaches 212 °F (100 °C) and 3775 psi, the disc will rupture and the gas contained in the cylinder will add to the fire already in progress.
3. As CNG is always a vapor, all CNG cylinders are designed without a relief valve.
4. The CNG cylinder(s) should be securely mounted, either vertically or horizontally, out of the way in an accessible area for easy operation of the CNG cylinder valve, observation of the CNG cylinder pressure gauge and the removal of the CNG cylinder.
5. As each CNG cylinder contains less thermal energy than two gallons of alcohol or kerosene fuel, but without their potential hazard of liquid leaks or spillage into the bilge, the CNG cylinder may be located in the area of the boat which would be suitable for the location of a pressurized alcohol or kerosene tank. See American Boat and Yacht Council Safety Standards for Small Craft, Section A-22 for recommendations covering CNG.

Copies may be ordered direct from A.B.Y.C., 3069 Solomon's Island Road, Edgewater, Maryland 21307. Telephone: (410) 956-1050. Baltimore line: (410) 974-8112. Fax: (410) 956-2737.

**NOTE:** By law, the CNG cylinder valve outlet fitting with its protective cap and chain, and the regulator system nut, Have **left-hand threads.** The cap and nuts are so marked with a slot.

6. The CNG cylinder valve outlet fitting does not require pipe dope or Teflon tape and should be clean and dry when attached to the regulation system nut to keep foreign materials out of the system.
7. Use a crescent wrench to tighten the regulation system nut to the CNG cylinder and valve connection. Tighten the nut as you would a welding tank or CO<sub>2</sub> cylinder, using approximately 50 ft-lbs. (68Nm) of torque.
8. If the CNG cylinder(s) is to be located on deck or exposed to water spray, point the regulation system so that water cannot run into the second stage (gray) regulator vent or into the body of the pressure gauge.
9. If the CNG cylinder(s) is to be located inside a cabin, enclosed in a lazarette hatch, or in an area with little ventilation, you must supply ample overhead ventilation in case of a leak or regulator malfunction.
10. Affix the caution label supplied with your Galley Range in the immediate vicinity of the cylinder in a place where it will be plainly visible.
11. The fuel line must be a type recommended for natural gas. This line may be purchased through any of the natural gas dealers in the US If you have any problems or questions regarding the fuel line or fuel system, contact:

East Coast

Corp Bros., Inc.  
Brook Street  
Providence, RI 02903  
Tel: (401) 331-8020

West Coast

Gas Systems, Inc.  
5361 Production Drive  
Huntington Beach, CA 92649  
Tel: (714) 891-2411

1. Push approved CNG hose onto the barbed brass fitting on the CNG outlet connection on the regulation system. Be sure the hose goes on all the way to the plastic guard. CNG hose seals well when it is pushed over the proper size barbed fitting - hose clamps are unnecessary and should not be used.

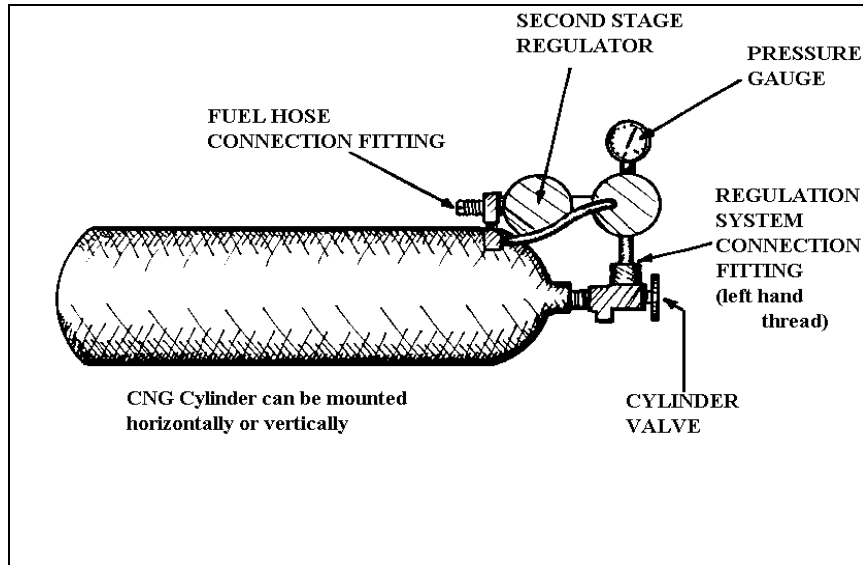

Recommended CNG System Installation

2. Run the hose from the CNG regulation system to the appliance with 6" minimum radius turns, so the hose does not kink and cut off or reduce the fuel supply causing unsatisfactory operation of the range. Note: Fuel pressure is less than .217 psi (15 mbar).
3. Use only continuous lengths of hose from the regulation system to the appliance with no tees or splices. Keep the number of fittings to an absolute minimum. Every connection is a potential leak!
4. Keep hose away from heat or abrasion. Use plastic ties or clamps to secure the hose to the boat structure or bulkheads. Fuel lines must be protected by close-fitting grommets and sealant where they pass through decks or bulkheads, and the passage must be made vapor-tight.
5. They should be installed so that they are readily accessible to inspection.

### **Fuel System Testing (LPG & CNG)**

Test your fuel system for leaks **each time** the cylinder supply valve(s) are opened for appliance use. Use the following procedure for the test.

First, close all range burner valves by turning the controls to the **OFF** position. Next, open the manual cylinder and solenoid valves and make a note of the reading on the pressure gauge. Now close the manual cylinder valve. The pressure should remain constant for at least 10 minutes. If it does not, gas is leaking out of the system.

The leak(s) should be located by applying a mixture of liquid of detergent and water to all connections and other suspect points and checking for bubbles. Do not attempt to locate leaks by using an open flame. Repair and re-test the system before putting it into operation.

For more detailed general instructions on the installation of Propane and CNG systems on boats, please refer to the American Boat and Yacht Council's pamphlets #A-1 and #A-22 respectively. These pamphlets may be ordered directly from A.B.Y.C., 3069 Solomon's Island Road, Edgewater, Maryland 21037. Telephone: (410) 956-1050. Baltimore line (410) 974-8112. Fax: (410) 956-2737.

### **Galley Range Installation - General**

1. Before installing your range, fill out the Warranty Registration Form that is printed on the last page of this manual and send it back to Force 10 within 10 days of purchase. Keep your model and serial numbers handy, as they will be required when ordering parts or requesting assistance.
2. Do not locate cabinet storage units or any combustible surfaces at any point directly above the range.
3. Force 10 recommends a 30" (75 cm) clearance between the range top and any unprotected combustible cabin top or bulkhead. This clearance may be reduced to a 20" (50cm) minimum if the overhead combustible surface is shielded with at least 1/4" (6mm) thick flame-retardant millboard topped with not less than No. 28 MSG sheet steel, 0.015" thick stainless steel, 0.024" thick aluminum, or 0.020" thick copper.
4. Gas consumes oxygen in the process of combustion. For this reason it is essential to **ventilate** any enclosure in which you plan to use your Galley Range. We recommend that at least nine square inches of fresh air ventilation be provided in the vicinity of the range.
5. Your Galley Range is equipped with a thermocouple device that will automatically turn off the gas supply within 15 seconds to any burner that might be accidentally extinguished. Force 10 specifically warns that your range should **not** be used as a cabin or space heater.

Force 10 manufactures a cabin heater specifically designed for the purpose of heating living space which is equipped with: (a) an oxygen depletion sensor which will automatically turn off the gas supply if the oxygen level in the cabin should fall more than 5% below the normal level, and (b) a stack to exhaust combustion-produced water vapor and carbon dioxide, which would otherwise saturate the air and create a humid “greenhouse” atmosphere in the cabin interior (extreme condensation around portholes, hatches, and on the exposed side is the usual sign). For functional reasons, these features - essential to the safe and comfortable operation of a cabin space heater - are not incorporated into the Galley Range.

6. The hinged burner grill and frame structure at the top of your range will become very hot during operation of the range top burners - do not attempt to swing up or lift it without wearing oven mitts. Keep children and pets away from the range when it is hot.
7. The whole range (including the oven door) becomes hot when the oven is being operated. The top portion of the back of the range becomes very hot during oven operation. Do not contact it with unprotected skin.
8. Always keep a Class ABC fire extinguisher mounted close by your Galley Range. Grease fires should be extinguished by smothering them with baking soda, or by using the ABC Class fire extinguisher.

### **Gimbaled Models**

**\*\* *This section applies only to models designed for suspension from gimbal bolts.***

Be sure to install the gimbal wall brackets so that your range will hang in the desired position in relation to both countertops and adjacent cabinets or bulkheads. For 3 or 4 burner models, there should be at least 1” (25mm) clearance between the back of the range and the nearest wall or bulkhead to allow free gimbal action. For 2 burner models, 4 1/2” (12cm) clearance is required for free gimbal action. (Because of the slant on the back of the 3 & 4 burner ranges, the clearance is less than what is needed for the 2 burner range).

Please refer to separate diagram and installation instruction sheet for the mounting dimensions and procedures for your specific model of range.

After installing the wall brackets and placing the range in position, drill a 3/8” (10mm) hole for the sliding pin gimbal lock. If the cabinet or fitting is not strong enough to hold the range securely in the locked position, install a metal plate (supplied) or a wooden block with a 3/8” (10mm) hole.

The bolt should be locked into the adjoining cabinet or bulkhead whenever the range is not in use to prevent it from swinging in rough seas. The bolt can be locked into either the “in” or “out” position by turning the knob clockwise. For added security in rough weather, bend up the retaining pin on the wall bracket over the gimbal knob.

### **Built-In Models**

\*\* *This section applies only to built-in models.*

Please refer to separate diagram and installation sheet for the mounting dimensions and procedures for your specific model of range.

On built-in model stoves, you must ventilate the back of the stove enclosure. This can be done by cutting holes at the side of the rear of the enclosure or across the back. Some people do a very neat job of installing our built-in stove, however, please realize your stove burners use a lot of oxygen. Therefore make sure you have access holes to supply plenty of fresh air, either below the stove or through the adjacent cabinet side panels. Minimum required area is 10 square inches (25 sq. cm).

Lift the hinged top burner grill and you will see the mounting hole.

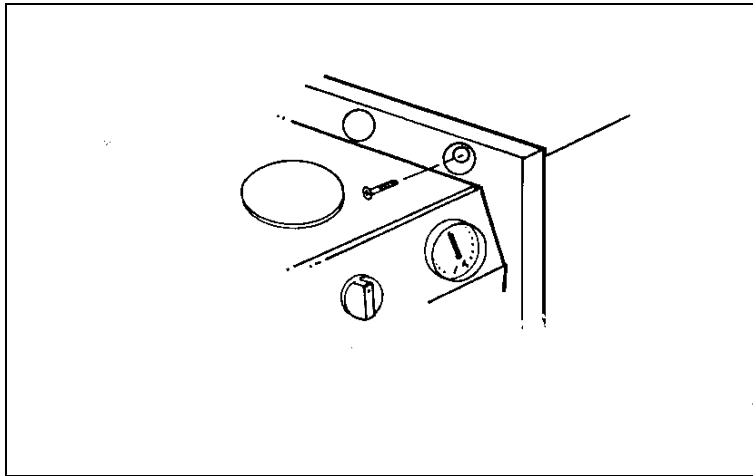

## **Operating Your Galley Range**

### **Lighting the Range Top Burners**

1. Before lighting, please ensure burner caps are placed on burners.
2. Read and comply with all safety instructions in the vicinity of the gas and in this manual.
3. Turn all control knobs to the **Off** position.

4. Open the manual cylinder and solenoid valves. (Turn the manual cylinder valve in the counterclockwise direction, and switch the solenoid valve to the open position.)
5. Push in control knob, (as far as it will go) and turn it counterclockwise to High. At the same time push the spark ignition button (small button beside control knobs) until burner is lit.
6. Sometimes the burner will sputter for a while before igniting. Give your range 10-15 seconds to purge the air out of the gas line.
7. Continue holding the burner control knob all the way in for about twenty (20) seconds after ignition. This will heat the thermocouple and allow the gas valve to stay open. The thermocouple is designed to cut off the gas supply to the burner if the flame should accidentally be extinguished.
8. This arrangement also ensures that the range is childproof to the extent that a simple twisting of the control knobs will not light any burners or allow gas to enter your boat.
9. If the ignition fails, turn the burner OFF and apply a lit match or lighter to it before turning it back to the High position.
10. You should now be able to set the flame to any desired level between High and Low by turning the control knob further in the counterclockwise direction.
11. To turn off the burner, turn the control knob clockwise to the Off position.
12. You must shut off both the solenoid and the manual gas cylinder valves whenever your vessel is unattended or if there is an emergency. Force 10 recommends that you also shut the cylinder valves off whenever your Galley Range is not in use.

### **Lighting the Oven and Broiler Burners - Manually Controlled Oven**

1. It is essential to the proper operation of your oven that the stainless steel heat plate be placed on the bottom of each grill hanger in the oven to ensure even heat distribution.
2. Light the oven burner using the procedure described in instructions 1 to 5 for lighting the range top burners.
3. Close the oven door carefully to ensure that the oven burner will not be extinguished.
4. Before lighting the broiler burner (not available in all models), make sure that the oven rack has been adjusted to position your food at the desired height.
5. Remember that broiling is a rapid process. **Broil With the Door Open.** Check your food often, and do not run the broiler for more than 20 minutes at a time.

### **Setting the Oven Temperature - Manually Controlled Oven**

The manually controlled oven has a thermometer mounted in the face to monitor the exact temperature of the oven.

After lighting the oven burner at the bottom of the oven, close the oven door and keep the burner on High until the temperature begins to reach the desired setting. Then turn the flame down, and adjust the setting until the temperature holds at the desired level.



Thereafter, you need only check occasionally to ensure that it remains stable.

## **Lighting the Oven and Broiler Burners - Thermostatically Controlled Oven**

1. It is essential to the proper operation of your oven that the stainless steel heat plate be placed on the bottom of each grill hanger in the oven to ensure even heat distribution.
2. Before lighting, please ensure the oven burner cap is placed on the burner.
3. Read and comply with all safety instructions in the vicinity of the gas and in this manual.
4. Turn all control knobs to the **Off** position.
5. Open the manual cylinder and solenoid valves. (Turn the manual cylinder valve in the counterclockwise direction, and switch the solenoid valve to the open position.)
6. Turn the control knob to the desired temperature or to the broil position.
7. Push in blue safety shut button. At the same time push the spark ignition button until burner is lit.
8. Close the oven door carefully to ensure that the oven burner will not be extinguished.
9. Before lighting the broiler burner (not available in all models), make sure that the oven rack has been adjusted to position your food at the desired height.
10. Remember that broiling is a rapid process. **Broil With the Door Open.** Check your food often, and do not run the broiler for more than 20 minutes at a time.

## **Thermostatically Controlled Oven Operation**

The burner will operate on high until the set temperature is reached. The burner will then automatically reduce to a low flame. During operation the burner never goes off.

When the temperature has been reached and the flame is very low be sure to close the oven door slowly when checking your food. To maximize the stability of this flame it was necessary for the burner to operate with a yellow flame when on high. Do not be alarmed. The combustion is still very clean and safe.

## **CARE AND MAINTENANCE**

Your Galley Range is constructed of one of the hardest, corrosion-resistant stainless steels available. However, the surfaces can be damaged if the proper care is not given. Please

follow these maintenance suggestions and you will have a good looking appliance for years to come.

1. Do not use any abrasive chemical cleaners on the inside or outside of your range. Any household liquid cleaner is recommended.
2. Use a clean cloth or sponge to apply cleaners.
3. Remove stains as quickly as possible before they become “set”.
4. Do not let food spills or burnt foods build up on any surface of your galley range.
5. You can use a household oven cleaner for the oven, but remember to follow the product manufacturer’s directions.

**Note:** **DO NOT** use these cleaners on the oven face plate or oven door, as the chemicals will remove the silkscreening.

6. Do not use steel wool or SOS-type pads to clean any part of your range. These products will embed fine steel particles in the surface of the stainless steel causing it to “bleed” (rust) in a marine environment. Use bronze wool or some other nonmetallic abrasive if you must. Be aware, however, that your range has a fine finish that can be scratched by some abrasive pads or cleansers.
7. If you purchased our optional bronze griddle to go with your Galley Range, you should be able to keep it clean using regular dishwashing detergent. We also recommend you use brass wool to keep it looking nice - rubbing with the grain. Do not use a copper polish or you will end up with green eggs and ham.

### **PROLONGED LAY-UP**

The Force 10 Gourmet Galley Range has been designed to have a long life with every day regular use. However, if you leave your boat unattended for a long period of time, particularly in high heat and humid conditions, the high temperature lubricant in the gas control valves may settle, resulting in difficulty in turning the control valves and possibly seizure of the valve.

In the event this should occur, do not use force to free-up the valve stem. It is best to remove the control panel from the range (pull off control knobs and remove thermometer - it will pull out). Remove the two small Phillips head screws on the front of each control valve. Once this is accomplished, you can remove the cap that holds the valve stem in the valve body. Inside the body is a shaft that may also be dirty. Using a pair of tweezers,



remove the shaft. **Remember its orientation inside the valve.** Carefully clean the valve stem and shaft using warm water or alcohol. Replace the shaft back in the valve, ensuring it is in the proper position. Lubricate the valve stem with a high-temperature lubricating grease (a small amount will do) and replace the valve and its associated cap. Secure the screw and replace the control panel.

**Note:** Do a soap test on the valve after assembly to ensure there are no leaks.

## **TROUBLESHOOTING**

If something should go wrong with the operation of your Galley Range, do not despair! Read this section carefully and follow our suggested remedies.

If these suggestions do not resolve the difficulty, contact Force 10 directly, or consult your dealer, quoting the model and serial number of your Galley Range. The serial number on gimballed models can be found on the bottom outside right panel, and on the built-in models it is on the bottom inside left panel.

### **Gas Smell**

1. Extinguish all open flames and smoking materials.
2. Close both manual and solenoid cylinder valves.
3. Make sure that all appliance valves are closed.
4. Ventilate all interior compartments thoroughly. Use a fan to push the air from the bottom of all compartments.
5. Maintaining as much ventilation as possible, open cylinder valves. Making sure that the appliance valves are still **closed**, apply a mixture of liquid detergent and water to all connections, checking for bubbles indicating a leak. Do **not** use a flame to check for leaks.
6. When repair of the leak(s) has been completed, test the system with the aid of the pressure gauge, using the procedure previously described for Fuel System Testing (Page 7).

### **Inadequate Heat - Flame Burning Low or Gas Out**

1. Your system may be low on fuel - check your tank pressure gauge.

2. The gas cylinder valve may not be fully open - make sure the handle is turned as far as it will go in the counterclockwise direction.
3. The burner orifice(s) may be obstructed - when cold, take off the burner cap, clean out the orifice and reinstall the part. If the broiler orifice needs to be cleared, added caution must be taken. Inside the orifice is a 'red ruby.' Check to ensure the 'red ruby' is still inside the orifice after cleaning. If it falls out, too much gas will be sent to the broiler, and a new orifice will be needed. Regardless of the orifice, only use alcohol or a Q-tip to clean the orifice. Never use metal to clean the orifice.
4. Sometimes LPG gas will not flow as readily if the outside temperature is very low - i.e. below freezing.

### **Ignition System Fails to Spark or Begins to Spark Slowly**

*\*\* Does not apply to 2-Burner models without broiler, which have piezo ignition.*

1. Check the battery to ensure that it is an AA 1.5 volt, that it is still giving power, and that it is installed the right way. The battery holder is located on the underside of the stove at the bottom front right hand corner. Install a new battery if necessary. In certain locations, salt air can corrode the battery holder.
2. Check to see whether there is 3/32" (2mm) gap between the spark plug head (which should be clean) and the burner rim, and that all the wires are securely connected to the spark ignition box located midway down the backside of the stove. A quick way to check is to press the spark button, and look to see if spark is sparking between terminals.
3. Remove control knobs and faceplate and check the wire connections at the back of the spark ignition switch. Check the operation of the switch with a circuit tester.
4. Remove the stove and disassemble so that each spark ignition connecting wire can be checked for shorts. Sometimes a minor nick in the wire will cause a short so the spark plug will not spark at that burner.
5. If none of the spark plugs will spark, first replace the battery and check again. If they still will not spark, order a replacement spark ignition box from Force 10.

Sometimes the burner will sputter for a while before igniting. Give your range 10-15 seconds to purge the air out of the gas line.

### **Burner Control Valve Fails to Stay Open When Valve Control Knob is Released**

1. There could be a problem with the thermocouple. The small upright attachment next to the burner on the range top is one end of the thermocouple.

The outside of the thermocouple is a copper tube. Inside the tube, insulated from it, is a nickel wire. These metals are in contact with each other only at the point that is exposed to the burner flame.

**Remember: The Burner Control Knob must be held all the way in for twenty (20) seconds after ignition in order to heat the thermocouple and allow the gas valve to stay open.**

When this point is heated by the burner flame, a small amount of electricity (1.5 millivolt) is generated. This electric current flows to the other end of the thermocouple that is tightened into the gas valve. Here it activates an electromagnet that keeps the valve open.

Should the burner accidentally be extinguished, electricity will no longer be generated, and the valve will be snapped back to the closed position by a stainless steel spring.

This is normally an isolated problem, as all thermocouples and ranges are tested at the factory. If necessary, however, remove the thermocouple following instructions 1 through 14 for replacing the thermocouple. Lightly sand the end that has been removed from the valve with very fine sandpaper. Replace in the valve and test. If this does not work the thermocouple must have failed and will have to be replaced.

You can also test the thermocouple by removing the end from the valve. Heat up the other end with a torch or another burner on your stove. By using a good quality voltmeter, put one lead on the outside of the thermocouple and the other one on the far cold end. If the thermocouple is okay, it will show 1.5 to 2.5 millivolts on your meter.

2. The electromagnet (solenoid) inside the valve may have failed and will have to be replaced.

## **REPLACING THE THERMOCOUPLE**

### **Tools Required**

- Phillips Screwdriver
- 5/16" (8mm) Open Wrench or Crescent Wrench
- 3/8" (10mm) Open Wrench

### **General Information**

1. Thermocouples are made out of two dissimilar metals. One end of each metal is fastened together. When this connection is heated up, a small amount of electricity is

created (1.5 millivolt) and can be measured between the other two ends of these wires.

2. The outside of the thermocouple is a copper tube, which acts as a conductor. The inside is an insulated nickel wire, which at the other end, is separated from the copper wire by a very small insulating washer. This end of the thermocouple screws into the gas valve, which contains an electromagnet.
3. When the thermocouple is heated, the electricity generated attracts the electromagnet in the valve and holds the valve open. If the flame is accidentally extinguished, the thermocouple cools, causing the electromagnet to spring back and close the valve.
4. If the thermocouple is not holding the valve open, check first that it is screwed into the valve tightly enough, as a loose connection will not transfer the 1.5 millivolt. If it has been tightened too much, the insulating washer will be crushed, shorting out the thermocouple, and so it will not generate the 1.5 millivolt, and must therefore be replaced. Ideally, the nut should be installed finger tight, plus a 1/4 turn with a wrench.

### **Replacement Instructions**

1. Get the stove on deck or on a bunk or table where you can work on it comfortably.
2. Remove both the back splash panel assembly complete with burner grill and the stove back panel (secured with Phillips screws).
3. Remove the screws at the top front edge which secure the front face panel.
4. Remove screws on top side edges.
5. Remove screws from upper and lower clamps that hold the oven lines and spark wire in position against the rear outer wall of the oven. *You may have to snip the plastic wire tie holding the spark leads together.*
6. The oven thermocouple tube is fastened down at the bottom of the oven by tie wrap (plastic clip), which needs to be removed.
7. Remove oven fuel line (bottom part only) with 1/2" (12mm) wrench.
8. Now slide the top burner tray out \* **about halfway** toward the back. Be careful with the tubes and wires. *If you remove any spark leads, mark them carefully for reinstallation.*

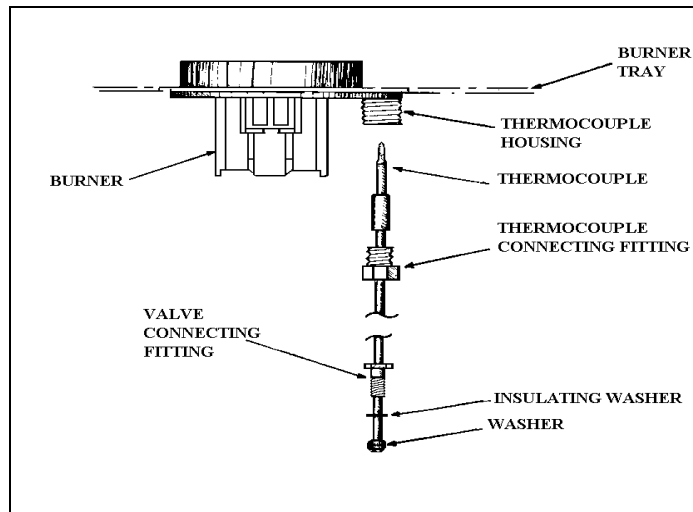

\* **Broiler Models:** The broiler fuel line must be removed before the top tray can be slid backward. The brass broiler orifice holder has a small Phillips screw in its right side. Completely remove this screw and pull out the broiler fuel feed line from the burner. Now you can slide the top tray back - be careful not to bend the broiler fuel line.

1. Remove the thermocouple end from the valve using a 5/16" (8mm) wrench or small crescent wrench.
2. Using a 3/8" (10mm) open wrench or crescent wrench, loosen the hex nut connecting the thermocouple to the burner until the thermocouple is loosened from the burner. Replace the thermocouple and proceed to Step 11.
3. Reverse the above procedure, being extremely careful when putting the end of the thermocouple into the valve. If you turn too tight, you will crush the insulating washer and need another new thermocouple. Ideally, the nut should be installed finger tight, plus a 1/4 turn with a wrench. **Do not force or cross thread anything.**
4. Make sure all gas lines, spark ignition wires, and thermocouples are not touching anything sharp.
5. When it is all back together, mix some liquid soap and water and do your standard test for leaks with your fuel system pressurized, and all control knobs turned to **OFF.**

### **To Replace the Electromagnet (Solenoid) (#1 on Page 21)**

When you remove the thermocouple from the control valve, remove the larger nut with a 9/16" (14mm) wrench. The electromagnet should fall out - if not, push the shaft where the knob should be and it will come out easily. Install the new electromagnet with the spring end first. Replace the nut, and re-install thermocouple back into the control valve.

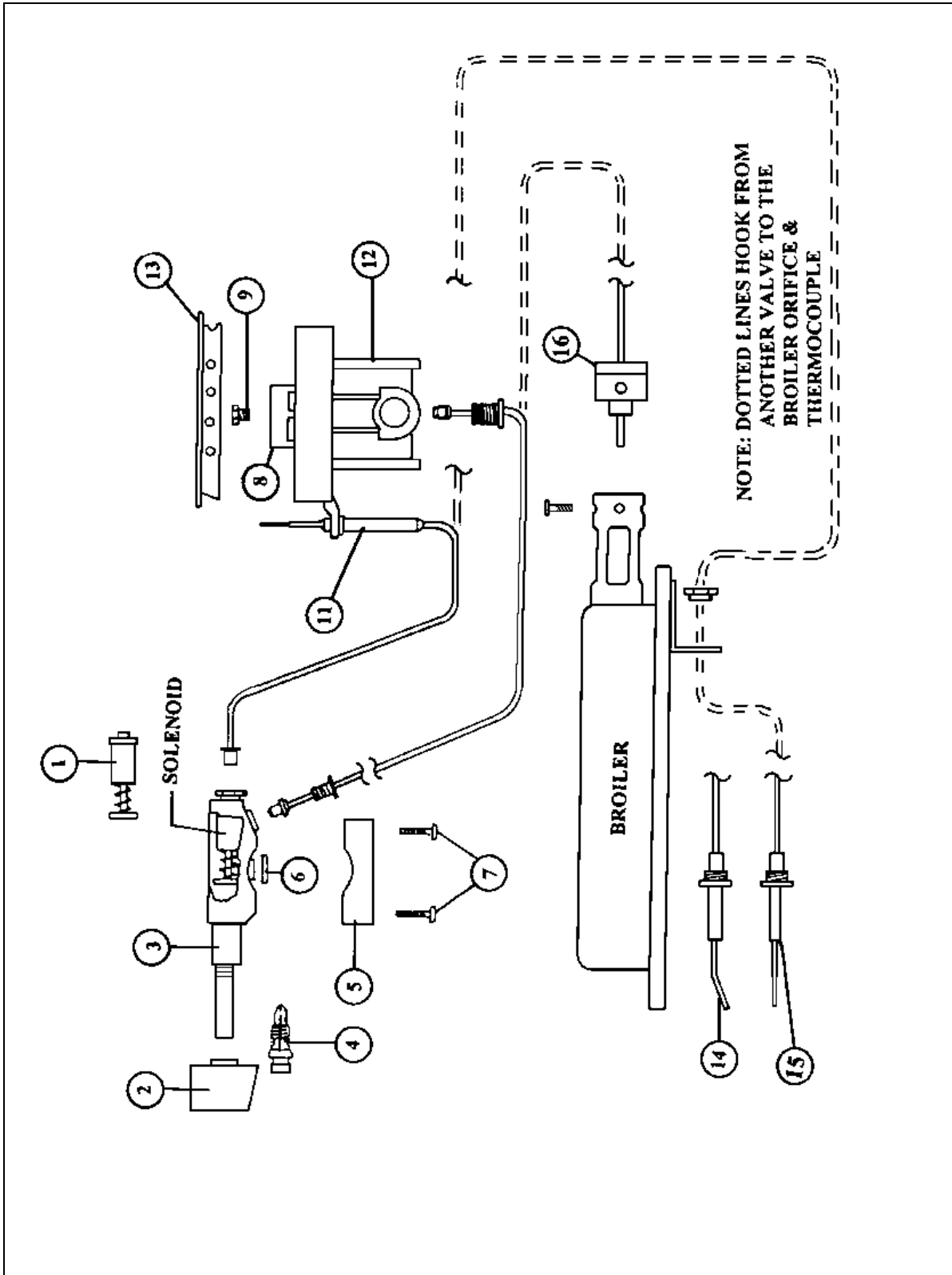

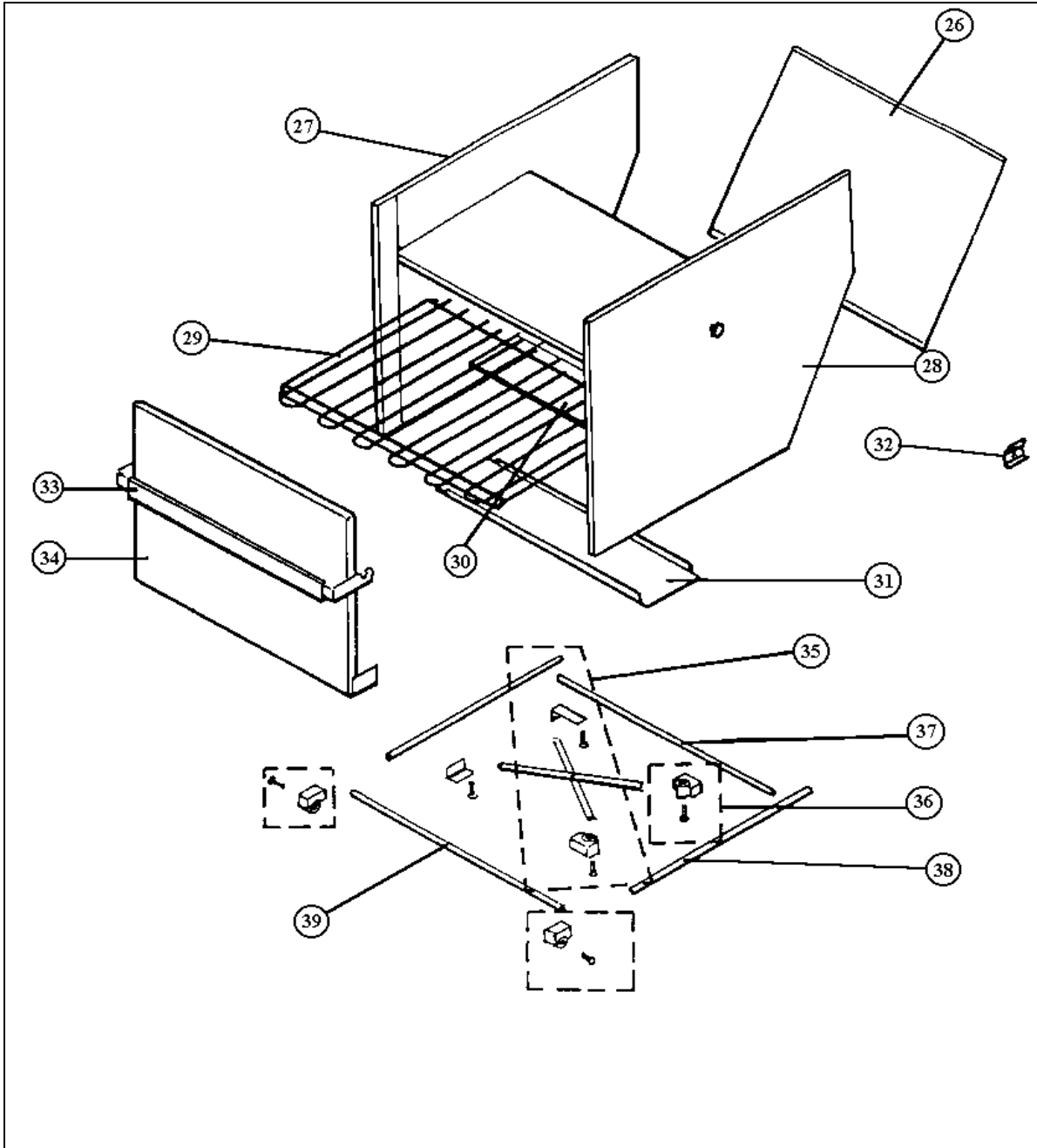

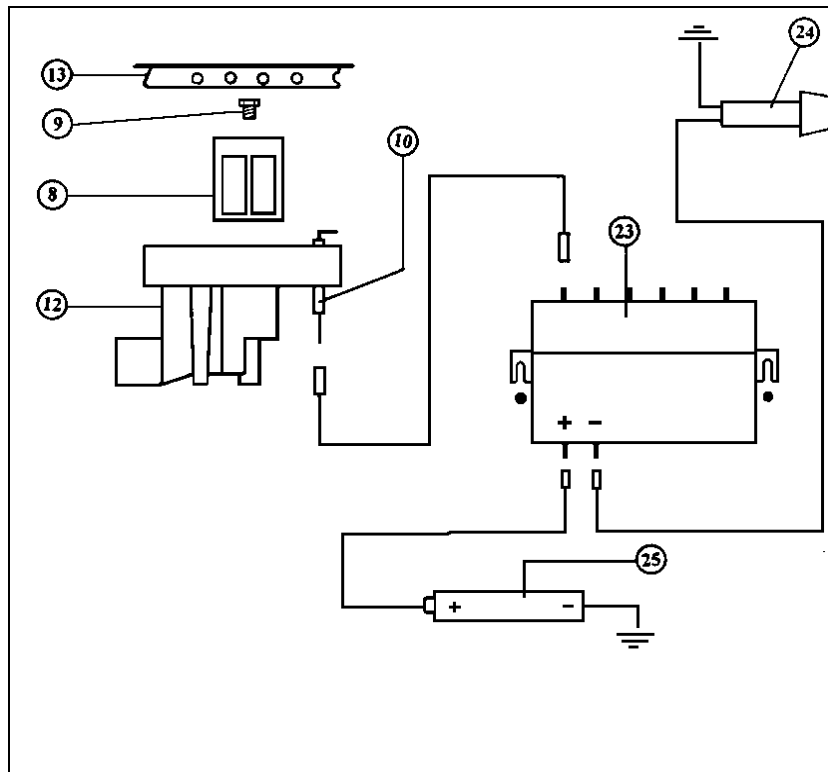
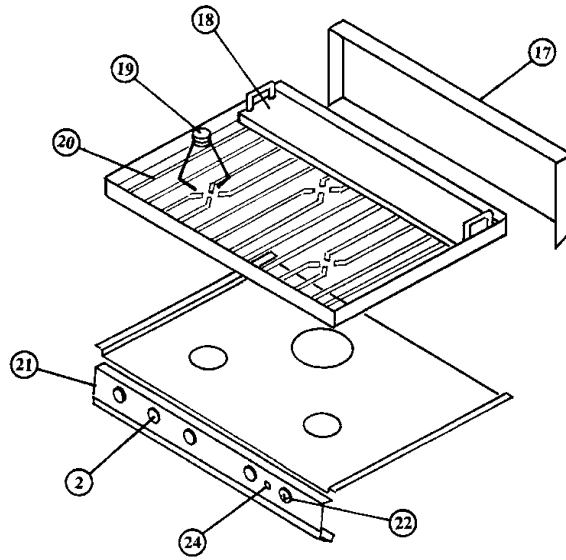

## PARTS BREAKDOWN

Number	Description	Part Number
1	Solenoid	†
2	Burner control knob	89010
3	Gas valve for small burner	†
	Gas valve for large burner	†
4	By pass**	*
5	Valve clamp	89080
6	Rubber gasket for valve	89031
7	bolt	87119
8	air basket - large - LPG/CNG	89001
	air basket - small - LPG/CNG	89002
9	#100 orifice (large burner - LPG)**	89045
	#77 orifice (small burner - LPG)**	89042
10	Burner spark plug	89063
11	Thermocouple	*
12	Burner housing - large	89012
	Burner housing - small	89013
13	Burner cap - large	89007
	Burner cap - small	89008
14	Broiler spark plug	*
15	Broiler thermocouple	89074
16	#68 orifice (broiler - LPG)**	89040
17	Top back panel assembly	*
18	Bronze griddle (optional)	86002
19	Pot holder assembly	86000
20	Top cooking grill	*
21	Control panel	*
22	Oven thermometer	89049
23	Spark ignition box 4 outlets	89060
	Spark ignition box 6 outlets	89061
24	Spark ignition switch	87113
25	Battery holder	87001
26	Back cover	*
27	Left stove side	*
28	Right stove side	*
29	Inside oven rack	*
30	oven heat plate	*
31	Stove bottom brace	*
32	Gimbal wall bracket	50507
33	Oven door handle	*
34	Oven door assembly - stainless steel	*
	Oven door assembly - glass	*
35	Cross bar assembly	*
36	Plastic block (door slider)	89052
37	Back brass rod	*
38	Side brass rod	*
39	Front brass rod	*

† Specify valve type when ordering.

\* Specify burner, stove model, and serial number when ordering.

\*\* For European sizes or CNG, please see table, pages 2 and 3.

### LIMITED WARRANTY

Force 10 Marine Ltd. warranties new products to the original consumer to be free from defective material(s) and workmanship while under normal use and service. This limited warranty extends for the following periods:

Propane / CNG Gourmet Galley Ranges	Two (2) Years
Propane / CNG Cooktop Stoves	Two (2) Years
Propane / CNG Cozy Cabin Heaters	One (1) Year
Propane Slimline Cabin Heaters	One (1) Year
Barbecue Grills	One (1) Year

### **Terms and Conditions**

During the warranty period, Force 10 Marine Ltd. will, at its option and without charge, repair and/or replace but not remove or re-install the faulty product

The buyer will return defective products to the address stated below. No product will be accepted by Force 10 Marine Ltd. without prior written or verbal authorization, and in accordance with instructions from Force 10 Marine Ltd. The authorization number must accompany returned merchandise. Return of defective products must be accompanied by written details of the problems and proof of purchase.

The buyer shall be responsible for shipping and insurance charges, if any, on the products returned for repair under the terms of this warranty. Force 10 Marine Ltd. will pay shipping of products returned to the buyer.

This limited warranty applies only to products that have been installed and used in accordance to printed instructions of Force 10 Marine Ltd. and does not cover improper use, vandalism, negligence or accidents.

As some states do not allow limitations on the length of an implied warranty nor limitations or exclusions of incidental or consequential damages, the above limitations or exclusions may or may not apply. This warranty gives you specific legal rights and you may also have other rights that vary from state to state.

**Model No.** \_\_\_\_\_ **Serial No.** \_\_\_\_\_

**This Range has been built to operate with the following pressure:**

**Propane/Butane:** \_\_\_\_\_ **mbar. Natural Gas:** \_\_\_\_\_ **mbar.**

**Force 10 Marine Limited  
23080 Hamilton Road  
Richmond, BC Canada V6V 1C9**

**FORCE 10 MARINE LTD.**



## WARRANTY REGISTRATION FORM

Purchaser's Name: \_\_\_\_\_

Address: \_\_\_\_\_

City: \_\_\_\_\_ State/Province: \_\_\_\_\_

Country: \_\_\_\_\_ Zip/Postal Code: \_\_\_\_\_

Telephone: \_\_\_\_\_

Model No.: \_\_\_\_\_ Serial No.: \_\_\_\_\_

Date Purchased: \_\_\_\_\_

Purchased for (Boat Model): \_\_\_\_\_

Purchased from (Dealer): \_\_\_\_\_

Dealer's Address: \_\_\_\_\_

City: \_\_\_\_\_ State/Province: \_\_\_\_\_

Country: \_\_\_\_\_ Zip/Postal Code: \_\_\_\_\_

Telephone: \_\_\_\_\_

Purchaser's Signature: \_\_\_\_\_ Date: \_\_\_\_\_

*This Warranty Registration must be filled in and mailed,  
within ten (10) days from date of purchase, to:*

**FORCE 10<sup>®</sup> MARINE LTD.**  
**23080 Hamilton Road**  
**Richmond, BC Canada V6V 1C9**  
**Tel (604) 522-0233**  
**Fax (604) 522-9608**

# **FORCE 10**

## **GOURMET GALLEY RANGES**

### **PROPANE AND NATURAL GAS MODELS**



## **OWNER'S MANUAL AND WARRANTY**

**FORCE 10 MARINE LTD.**  
23080 HAMILTON ROAD  
RICHMOND, BC CANADA V6V 1C9  
TEL: (604) 522-0233  
FAX: (604) 522-9608

## TABLE OF CONTENTS

	<u>PAGE</u>
Introduction.....	1
Safety and Installation.....	2
Gas Pressures .....	2
Propane and Butane (LPG) Fuel Systems.....	3
Natural Gas (CNG) Fuel System.....	5
Fuel System Testing (LPG & CNG) .....	7
Galley Range Installation - General .....	8
Gimballed Models.....	9
Built-In Models .....	10
Operating Your Galley Range.....	10
Lighting the Range Top Burners.....	10
Lighting the Oven and Broiler Burners - Manually Controlled Oven .....	11
Setting the Oven Temperature - Manually Controlled Oven .....	11
Lighting the Oven and Broiler Burners - Thermostatically Controlled Oven.....	12
Thermostatically Controlled Oven Operation.....	12
Care And Maintenance.....	13
Prolonged Lay-Up.....	13
Troubleshooting .....	14
Gas Smell.....	14
Inadequate Heat - Flame Burning Low or Gas Out.....	15
Ignition System Fails to Spark or Begins to Spark Slowly .....	15
Burner Control Valve Fails to Stay Open When Valve Control Knob is Released....	16
Replacing The Thermocouple.....	17
To Replace the Electromagnet (Solenoid) .....	18
Parts Breakdown .....	22
Limited Warranty .....	23